

GMC-YC-06 Magnetic Catch

Features

- Strong die-cast body
- Small body with strong magnetic force with use of neodymium magnet
- Can be installed vertically or horizontally

Notes

- Max. temperature: 80°C
- Recommended screws: M3 Pan head screw

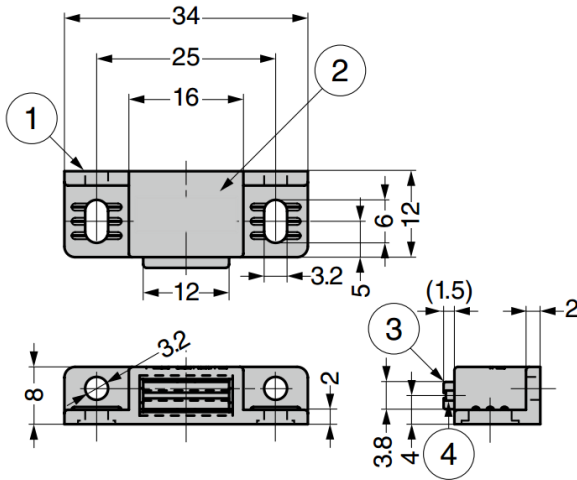

No.	Part Name	Material	Finish
①	Body	Zinc Alloy (ZDC)	Nickel
②	Case Bracket	Stainless Steel (SUS304)	-
③	Yoke	Steel	Clear Zinc Chromate (Trivalent)
④	Magnet	Neodymium	Nickel

Part No.	Magnetic Force	
GMC-YC-06	44.1 N	4.5 kg

GMC12 Magnetic Catch

Parts Included

- Counter plate

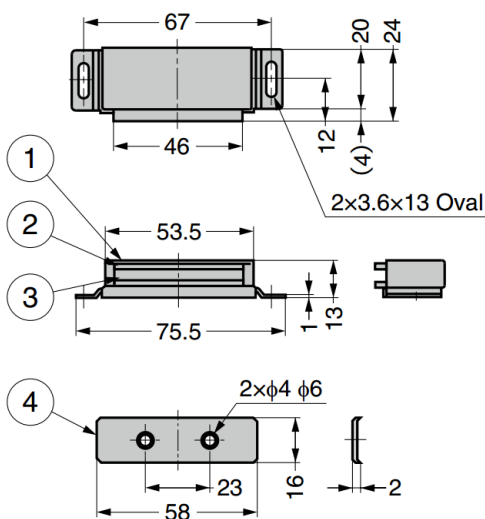

Part No.	Finish	Magnetic Force	
GMC12	Gold Anodised	49 N	5 kg
GMC12S	Paint / Metallic Brown	88.2 N	9 kg

No.	Part Name	Material	Finish
①	Body	Aluminium Alloy	MC12: Gold Anodised MC12S: Paint/Metallic Brown
②	Yoke	Steel (SPCC)	Clear Zinc Chromate (Trivalent)
③	Magnet	Ferrite	-
④	Counter Plate	Steel (SPCC)	MC12: Clear Zinc Chromate (Trivalent) MC12S: Chrome